



 **Delta** Baño



VISION OF HOME

"In Delta baños, we think that the bathroom is an important place at home. It is the room where our day begins and finishes. And here, more than anywhere else, we look for comfort, order and harmony.

Our collection is available in a wide variety of finishes, textures and materials which allow us to design new projects completely integrated in any possible ambient. Our exclusive designs give a different and personal touch to your home.

We have got the technical resources to make good quality and durability finish, way over the standards demanded by the market. However, each and every composition is different and unique. Its production is made under request and made in an artisanal way.

We always design functional and warm spaces in order to improve your home." Ana R. Medrano, CEO.

Small details are what make us feel at home.

VISION DE FOYER

"Chez Delta Bains nous concevons la salle de bains comme partie relevante du foyer. Ici commence et finit notre journée. Et ici plus qu' ailleurs, nous avons recherché commodité, ordre et harmonie.

Nos collections disposent d'une gamme sélecte et variée autant dans ses matériels, comme dans ses textures et ses achevés, ce qui permet des créations où nos compositions peuvent être intégrées dans n'importe quel projet d'intérieur.

Nos créations sont exclusives et apportent une touche différente et personnelle à votre déco.

Nous disposons de ressources techniques qui nous permettent d'obtenir des finitions d'une qualité et d'une durabilité bien au-dessus des exigences du marché. Par conséquent, chaque composition est unique. La production se réalise sous commande, et se fabrique de manière artisanale.

Nous concevons des espaces chaleureux et fonctionnels qui apportent bien-être au foyer." Ana R. Medrano, Gérante.

Les petits détails sont ceux qui nous font sentir chez nous.



VISIÓN DE HOGAR

En Delta concebimos el baño como una parte importante del hogar. Aquí comienza y termina nuestro día. Y aquí más que en ningún otro lugar, buscamos comodidad, orden y armonía.

Nuestras colecciones disponen de una variada y seleccionada gama de materiales, texturas y acabados, que permiten diseñar composiciones capaces de integrarse en cada proyecto de interiorismo.

Nuestros diseños exclusivos aportan un toque diferente y personal a la decoración.

Disponemos de recursos técnicos que nos permiten obtener acabados de calidad y durabilidad, por encima de lo exigido en el mercado. Sin embargo cada composición es única. Su producción se realiza bajo encargo y es fabricada de modo personalizado.

Buscamos espacios cálidos y funcionales que aporten bienestar en el hogar.

Ana R. Medrano. Gerente.

Los pequeños detalles
son los que nos hacen
sentir en casa.



 **Delta** Baño

NUESTRAS COLECCIONES

our collections
nos collections

TIRADOR LINEAL

lineal handle
poignées linéaire

Modelo TUDELA

Modelo ALVA

PUERTA TRIDIMENSIONAL

tridimensional door
porte tridimensionnelle

Modelo ARTICA

Modelo KALA

APERTURA POR GOLA

handleless system
ouverture par système gola

Modelo 45° ALUMINIO

Modelo 45° LACADO

PUERTA RECTA

standard door
porte droite

Modelo SOTO ALTO BRILLO

Modelo NATURA 2

Modelo YERGA

Modelo SOTO ANTIHUELLAS

EQUIPAMIENTOS Y ACCESORIOS

equipment & accessories / équipements et accessoires

DETALLES TÉCNICOS technical details / détails techniques

TOALLEROS INTEGRADOS embedded towel holders / porte-serviettes intégrés

LAVABOS PORCELÁNICOS ceramic washbasin / lavabos de porcelaine

LAVABOS ACRÍLICOS acrylic washbasin / lavabos acryliques

ESPEJOS mirrors / miroirs

ILUMINACIÓN lighting / illumination

ACABADOS

finishes / finitions

COLORES Y ACABADOS TENDENCIA

trendy colours and finishes / finitions en couleurs tendance

EMPRESA

company / entreprise

HISTORIA, CALIDAD & DIFERENCIACIÓN

history, quality and differentiation / histoire, qualité et différenciation



TUDELA



ALVA



ARTICA



KALA



MOD. 45°
ALUMINIO





OLITE. 45°
LACA



SOTO
ALTO BRILLO



NATURA 2



YERGA



SOTO
ANTIHUELLAS





Delta Baño

las colecciones

our collections / les collections



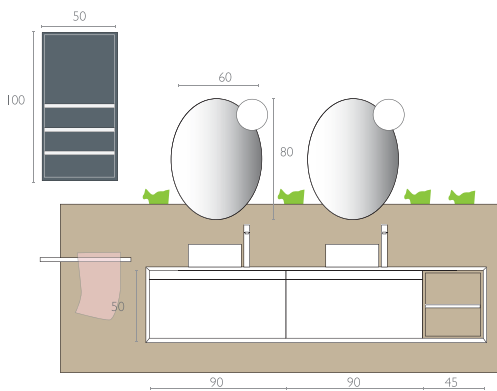

TUDELA

TIRADOR LINEAL

Mueble enmarcado en cerámica de 10 mm con decorati-
vo en laminado roble claro veta sincronizada. Puertas
lacadas en blanco. Decorativo pared en laca petróleo
con estantes roble. Interior cajones y divisores lacados en
blanco. Espejo ovalado con apliques iluminación.

LINEAL HANDLE. Cabinet framed by 10mm thick
ceramic with an open unit made of light oak laminate
with embossed grain. White lacquer doors. Wall open
unit in color petroleum lacquer with oak shelves.
Drawers interior and dividers in white lacquer.
Oval mirror with lighting fixtures.

Poignée linéaire. Meuble encadré en céramique de
10mm ,élément décoratif en chêne clair laminé à veinage
synchronisé. Portes laquées en blanc. Élément décoratif
pour mur en laque couleur pétrole avec étagères en
chêne. Intérieur des tiroirs et des diviseurs en laqué
blanc. Miroir ovale avec appliques d' illumination.







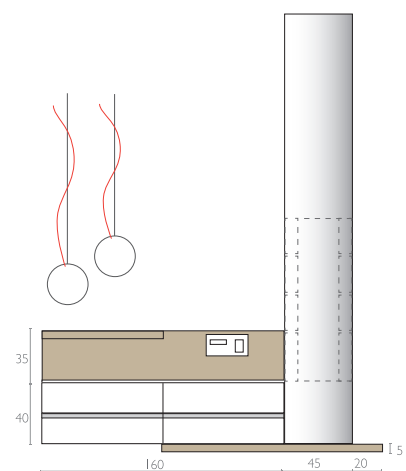

ALVA

TIRADOR LINEAL

Puertas en laminado blanco con tirador aluminio integrado. Interior cajones y divisores en laminado blanco. Estantes de roble precom barnizado antihumedad. Decorativos detrás del espejo en laca césped.

Lineal handle. Doors in white laminate with embedded aluminium handle. Drawers interior and dividers in white laminate. Precom oak shelves with moisture-proof varnished. Open units behind the mirror in grass lacquer.

Poignée linéaire. Portes en laminé blanc avec poignée en aluminium intégrée. Intérieur de tiroirs et diviseurs en laminé blanc. Étagères en chêne precom verni antihumidité. Déco derrière le miroir en laque couleur gazon.



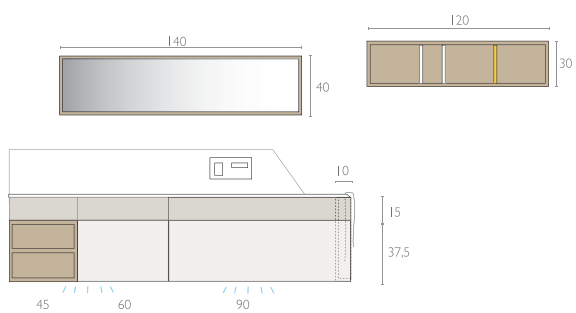

ARTICA Design Estudiosat

PUERTA TRIDIMENSIONAL

Puertas tridimensionales lacadas en blanco con apertura por push. Encimera biselada con toallero mecanizado. Decorativos en laminado roble claro. Cajones en acero lacado blanco con bases y separadores roble. Base iluminada por leds de bajo consumo.

Tridimensional door. White lacquer doors with push-opening system. Bevelled worktop with embedded mechanized towel holder. Open units in light oak laminate. Drawers in white lacquered steel with oak base and dividers. Base illuminated by energy-efficient LEDs.

Une porte tridimensionnelle. Portes tridimensionnelles laquées en blanc, avec ouverture par push. Plan biseauté avec un porte-serviettes mécanisé. Éléments décoratifs en laminé chêne clair. Tiroirs en acier laqué en blanc avec bases et séparateurs en chêne. Une base illuminée par leds de basse consommation.







▼ diseño exclusivo

KALA Design Estudiosat

PUERTA MECANIZADA CON UÑERO

Mueble lacado en gris arena. Puerta con uñero. Encimera, decorativos y patas en laminado roble claro. Cajones en acero lacado blanco con compartimentos separadores. Muebles auxiliares lacados con apertura push.

Tridimensional door. Laquer grey sand cabinet. Door with finger-pull. Worktop, open units and legs made of light oak laminate. White lacquer steel drawers with dividers. Lacquer auxiliary cabinets with push-opening system.

Une porte tridimensionnelle. Meuble laqué en couleur gris-sable. Porte avec onguet. Plan, éléments décoratifs et pattes laminés en chêne clair. Tiroirs en acier laqués en blanc avec compartiments séparateurs. Meubles auxiliaires laqués et ouverture push.

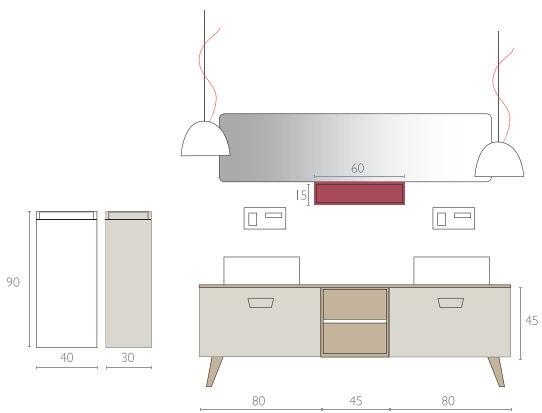



▼ diseño exclusivo

MOD. 45° ALUMINIO

APERTURA POR GOLA

Muebles, enmarcado y gola en laminado nórdico claro con veta sincronizada. Puertas en laminado pino oscuro con bisel 45° en aluminio lacado en blanco. Interior cajones y divisores en acero lacado blanco. Decorativo mueble y espejo en laca pink + aplique led bajo consumo.

Handleless system. Furniture, frame and handleless system made in light Nordic laminate with embossed grain. Doors in dark pine laminate with a 45° bevelled finger-pull in white lacquered aluminium. Drawers interior and dividers made of white lacquered steel. Open units and mirror painted in pink lacquer + energy-efficient LED lamps.

Ouverture par système gola. Meubles, encadrements et finitions en laminé nordique clair et veinage synchronisé. Portes en laminé sapin foncé avec biseau 45° en aluminium laqué en blanc. Intérieur de tiroirs et diviseurs en acier laqués en blanc. Élément décoratif et miroir laqués en ton pink + applique led basse consommation.



Diseño exclusivo canto aluminio lacado

Exclusive design 45° bevelled finger-pull in aluminium
 Modèle exclusif biseau 45° en aluminium

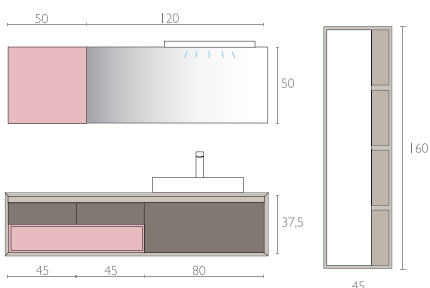



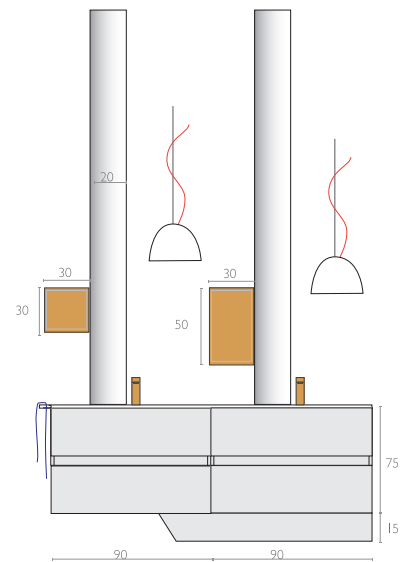

OLITE 45° LACA

APERTURA POR GOLA

Mueble lacado en gris nube con puertas bisel 45°. Interior cajones y divisores en acero lacado gris. Decorativos y espejo en laca calabaza y laminado roble mediterráneo. Zócalo alto con forma.

Handleless system, Lacquer model. Cabinet in colour cloud grey lacquer with a 45° bevelled door. Drawers interior and dividers made of grey lacquered steel. Open units and mirror in pumpkin lacquer and Mediterranean oak laminate. Plinth in an original shape.

Ouverture par système gola. Mod. 45 ° laqué. Meuble laqué en ton gris-nuage avec portes à biseau 45 °. Intérieur de tiroirs et diviseurs en acier laqués en gris. Éléments décoratifs et miroir laqué en ton potiron et laminé en chêne méditerranéen. Socle haut avec forme.





SOTO ALTO BRILLO

PUERTA RECTA

Muebles en textil plata acabado laca poliéster alto brillo. Con apertura cajones por push. Decorativo y zócalo en laminado gris arena. Espejos con iluminación frontal.

Standard door. Cabinet in silver textile, exterior finish: high gloss polyester lacquer. Drawer with push-opening system. Open unit and plinth in sand grey laminate. Mirror with frontal lighting.

Porte droite. Meubles en textile argenté finitions en laque polyester de haute brillance. Ouverture de tiroirs système push. Élément décoratif et socle en laminé gris-sable. Miroirs à illumination frontale.

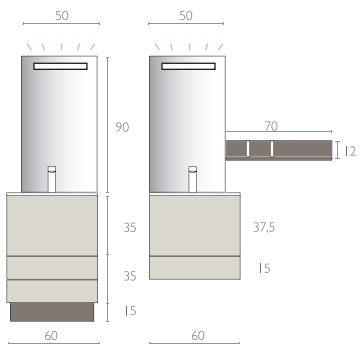



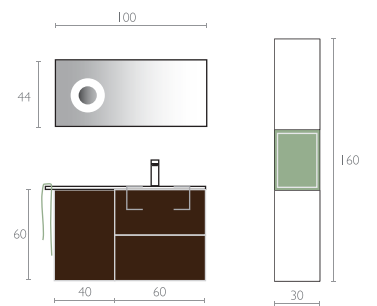

NATURA 2

PUERTA RECTA

Mueble en laminado nogal con tirador integrado. Decorativos en laminado blanco y gris piedra, con tirador mecanizado en canto. Espejo con aumento y luz.

Standard door. Cabinet made of walnut laminate with embedded handle. Open units in white and stone grey laminate, with mechanized finger-pull on the edging. Magnifying mirror with lighting fixtures.

Porte droite. Meuble en laminé noyer et poignée intégrée. Éléments décoratifs en laminé blanc et gris-pierre, avec poignée mécanisée sur un chant. Miroir d'augmentation et lilluminaton.





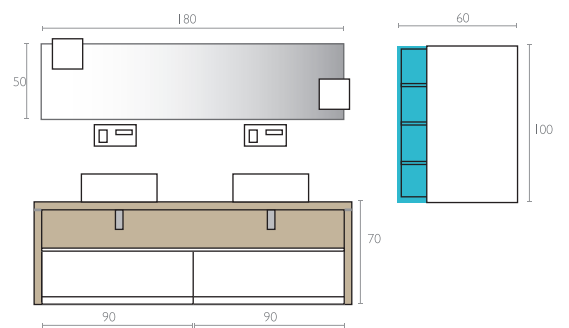

YERGA

PUERTA RECTA

Cajones en laminado blanco con tirador yerga integrado. Enmarcado 50 mm en laminado roble claro veta sincronizada. Decorativo en laminado blanco y azul lago. Espejo enmarcado en aluminio con apliques led bajo consumo.

Standard door. Drawers in white laminate with embedded Yerga handle. Frame of 50mm in light oak laminate with embossed grain. Open unit in white and lake blue laminate. Mirror framed by aluminium with energy-efficient LED lamps.

Porte droite. Tiroirs en laminé blanc avec poignée yerga intégrée. Encadrement 50 mms en laminé chêne clair et veinage synchronisé. Élément décoratif en laminé blanc et bleu lac. Miroir encadré en alu et appliques led de basse consommation.

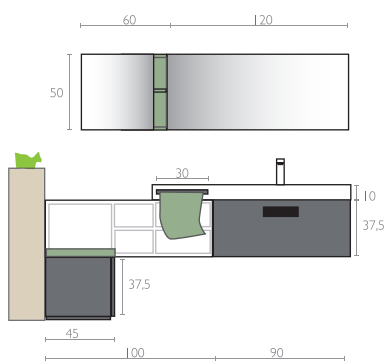

SOTO ANTIHUELLAS

PUERTA RECTA

Muebles en soto antihuellas gris marengo con uñero integrado. Encimera con compartimento y frente toallero. Espejo con mueble decorativo en laca gris topo.

Cabinets made of anti-fingerprints soto, colour Marengo grey, with embedded finger-pull. Worktop with compartment and towel holder. Mirror with an open unit in mole grey lacquer.

Porte droite. Meubles soto anti-empreintes en ton gris-marengo et ongles intégré. Plan à compartiment et frontal porte-serviettes. Miroir avec meuble décoratif en laque ton gris-taupe.









▼ **Delta** Baño

equipamientos
y accesorios

equipment & accessories / équipements et accessoires

EQUIPAMIENTOS Y ACCESORIOS DETALLES TÉCNICOS

equipment & accessories
/ équipements et accessoires
technical details / détails techniques



Cajones internos en acero lacado blanco. Extracción total.

Internal drawers in white lacquered steel.
Full extraction.
Tiroirs intérieurs en acier laqué blanc.
Extraction totale.

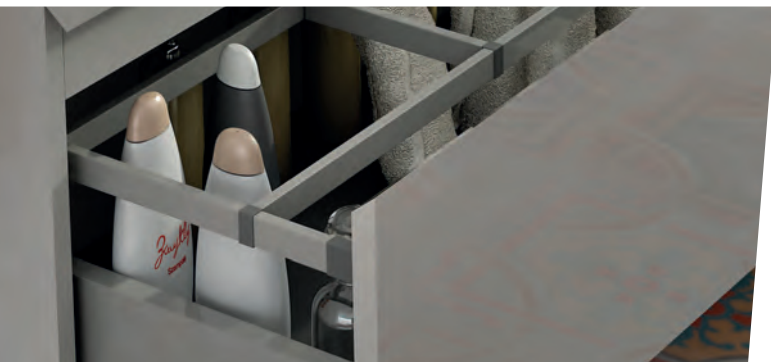

Cajones en acero lacado gris. Extracción total.

Drawers in grey lacquered steel.
Full extraction.
Tiroirs en acier laqué gris.
Extraction totale.



Separadores interiores en acero.

Interior dividers made of steel.
Séparateurs intérieurs en acier.



Separadores interiores en laminado.

Interior dividers made of laminate.
Séparateurs intérieurs en laminé.



Separadores interiores en roble.

Interior dividers made of oak.
Séparateurs intérieurs en chêne.

Mismo acabado interior y exterior.

Same finish in both, interior and exterior.

Mêmes finitions intérieures et extérieures.



Decorativos en 10 mm.

Open units of 10mm.

Éléments décoratifs en 10mm.



Decorativos en 19 mm.

Open units of 19mm.

Éléments décoratifs en 19mm.



Baldas interiores igual que armazón.

Interior shelves in same colour as carcass.

Étagères intérieures pareilles que la structure.



Baldas cristal.

Glass shelves.

Étagères en cristal.

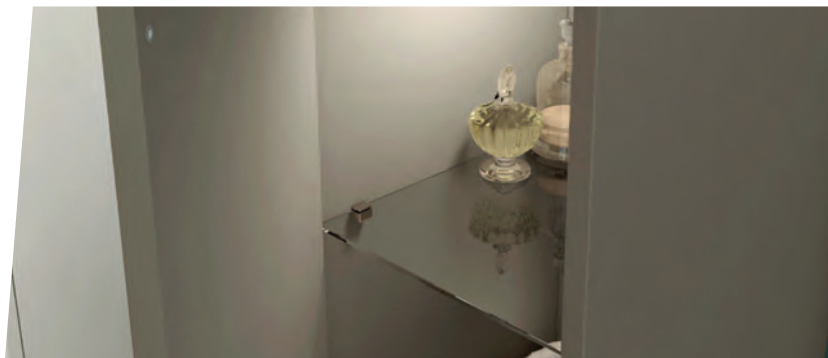

Zócalos especiales.

Special plinth.

Socles spéciaux.



EQUIPAMIENTOS Y ACCESORIOS LAVABOS PORCELÁNICOS

equipment & accessories / équipements et accessoires
ceramic washbasin / lavabos en porcelaine.

[Medidas en cm.]

Size in cm. / Mesures en cm.



LP01 - Lavabo Modular Curvo

Curve Modular Basin / Lavabo Modulaire Vasque Courbe

1 Poza fondo 46: 61 / 71 / 76 / 81 / 91 / 101 / 121

1 basin depth 46 / 1 bac fond 46 :

1 Poza fondo 39,5: 61 / 71 / 81 / 91 / 101

1 basin depth 39,5 / 1 bac fond 39,5

2 Pozas fondo 46: 121

2 basins depth 46 / 2 bacs fond 46

1 Poza fondo 46: desplazado der/ izq: 91 / 101 / 121

placed right - left depth 46 / emplaced à droite - à gauche fond 46 :

LP02 - Lavabo Modular Recto

Straight Modular Basin / Lavabo Modulaire Vasque Droite

1 Poza fondo 46: 61 / 81 / 101

1 basin depth 46 / 1 bac fond 46 :

2 Pozas fondo 46: 121

2 basins depth 46 / 2 bacs fond 46



LP03 - Sobreencimera rectangular hueco para grifo 61 x 37,5 x 10

Counter-top rectangular tap 61 x 37,5 x 10

Surplan rectangulaire robinet 61 x 37,5 x 10

LP04 - Sobreencimera cuadrado hueco para grifo 45 x 42 x 12

Counter-top square tap 45 x 42 x 12

Surplan carré robinet 45 x 42 x 12



LP05 - Sobreencimera cuadrado 40 x 40 x 12

Counter-top square 40 x 40 x 12

Surplan carré 40 x 40 x 12

LP06 - Sobreencimera circular Ø43 x 14 Ø35 x 14 Ø50 x 14

Counter-top round Ø43 x 14 Ø35 x 14 Ø50 x 14

Surplan circulaire Ø43 x 14 Ø35 x 14 Ø50 x 14

LAVABOS ACRÍLICOS

[Medidas en cm.]

Acrylic washbasin / Lavabos acrílicos

Size in cm. / Mesures en cm.

Encimeras de 1,2 cm de espesor, disponibles en cualquier medida hasta 51 cm de fondo y 200 cm de frente. Posibilidad de cortes, retranqueos y copetes hasta 5 cm. 2 pozas a partir de 121 cm.

Worktops of 1,2 cm thick are available in any size up to 51 cm deep and 200 cm width. Possibility of cuts, setbacks and upstands up to 5cm. 2 basin from 121 cm width.

Plans de 1,2 cm d'épaisseur, disponibles dans n'importe quelle mesure jusqu'à 51 cm de fond et 200 cm de front. Possibilité de coupes, reliefs jusqu'à 5 cm. 2 bacs à partir de 121 cm.



LA01 - Poza Rectangular 50 x 30 x 12
Rectangular Basin 50 x 30 x 12
Vasque Droite 50 x 30 x 12



LA02 - Poza Ovalada 60 x 32 x 12
Curve Basin 60 x 32 x 12
Vasque Courve 60 x 32 x 12



LA03 - Poza Rectangular Redondeada 45 x 25 x 11
Rectangular Basin 45 x 25 x 11
Vasque Droite 45 x 25 x 11



Según diseño cliente
As client design shows
Au goût du client

TOALLEROS INTEGRADOS

embedded towel holders / porte-serviettes intégrés



Toallero lateral enmarcado con decorativo
Lateral towel holder framed by open unit.
Porte-serviettes latéral encadré avec élément décoratif.



Toallero lateral
Lateral towel holder.
Porte-serviettes latéral.



Toallero frontal
Frontal towel holder.
Porte-serviettes frontal.

EQUIPAMIENTOS Y ACCESORIOS

ESPEJOS [Medidas en cm.]

equipment & accessories / équipements et accessoires
mirrors / miroirs

Size in cm. / Mesures en cm.

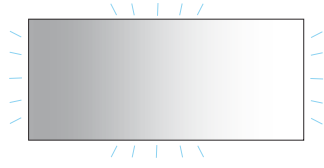

Recto 4 cantos pulido con o sin retroiluminación leds

Standard 4 polished edges, with or without LED backlight.

Droit 4 chants polis avec ou sans retro-illumination de leds.

ANCHO/WIDTH/LARGEUR: MIN 40 MAX 180
ALTO/HEIGHT/HAUTEUR: MIN 30 MAX 100



Recto 4 cantos pulido iluminación lateral

Standard 4 polished edges, lateral light.

Droit 4 chants polis illumination latérale.

ANCHO/WIDTH/LARGEUR: MIN 40 MAX 180
ALTO/HEIGHT/HAUTEUR: MIN 40 MAX 100



Recto 4 cantos pulido iluminación superior

Standard 4 polished edges, top light.

Droit 4 chants polis illumination supérieure.

ANCHO/WIDTH/LARGEUR: MIN 40 MAX 180
ALTO/HEIGHT/HAUTEUR: MIN 40 MAX 100



Recto con luz y aumento

Standard with light and augment

Droit avec lumière et augmentation

100 X 44
90 X 44



Recto marco aluminio 1mm gris o negro

Standard 1mm aluminium frame, colour black or grey

Droit encadrement aluminium 1mm gris ou noir

ANCHO/WIDTH/LARGEUR: MIN 40 MAX 180
ALTO/HEIGHT/HAUTEUR: MIN 30 MAX 100

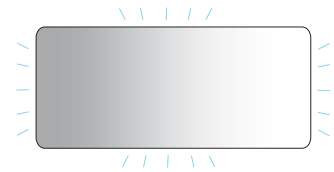

Esquinas redondeadas con o sin retroiluminación leds

Rounded corners, with or without LED backlight.

Coins arrondis avec ou sans rétro-illumination de leds.

ANCHO/WIDTH/LARGEUR: MIN 40 MAX 120
ALTO/HEIGHT/HAUTEUR: MIN 30 MAX 100

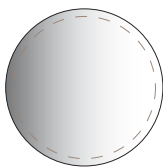

Redondo

Round
Rond

Ø MIN 50 MAX 90

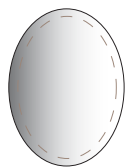

Oval

Oval
Ovale

80 X 60



Enmarques de todo tipo, tablero laminado o lacado + espejo

Any kind of frames, laminate or lacquer board + mirror
Encadrements de tous types, panneau laminé ou laqué + miroir

CUALQUIER MEDIDA/ANY SIZE/N'IMPORTE QUELLE MESURE: MIN 30

EQUIPAMIENTOS Y ACCESORIOS ILUMINACIÓN

equipment & accessories / équipements et accessoires
lighting / illumination



Line Aplique Led 30/45/60/80/100 cm IP 44
Blanco o Cromo
Wall LED lamp 30/45/60/80/100 cm IP 44
Applique Led 30/45/60/80/100 cm IP 44



Cube Aplique Led 11/20/30 cm IP 44
Blanco o romo
Wall LED lamp 11/20/30 cm IP 44
Applique Led 11/20/30 cm IP 44



Foco cuadrado Led IP 54
Square LED lamp IP 54
Spot carré Led IP 54



Foco LED Samsung 8 cm IP45
LED lamp Samsung 8 cm IP45
Spot Led Samsung 8 cm IP45



Aplique 25 cm 11/22W IP 44
Wall lamp 25 cm 11/22W IP 44
Applique 25 un cm 11/22W IP 44

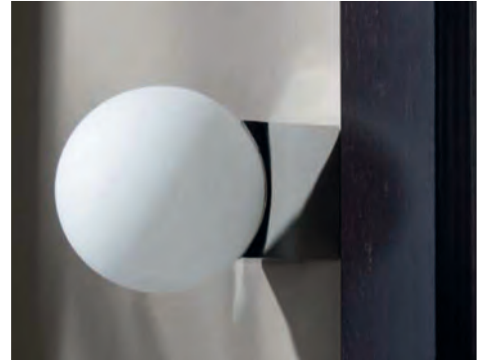

Aplique Ø9 cm 40W IP 44
Wall lamp Ø9 cm 40W IP 44
Applique Ø9 cm 40W IP 44

BLANCO

GRIS NUBE

GRIS MARENGO

NEGRO

MAGNOLIA

GRIS HUESO

GRIS PIEDRA

GRIS ARENA

GRIS TOPO

AZUL NIEBLA

AZUL LAGO

AZUL PETROLEO

ROJO

BURDEOS

PINK

CÉSPED

CALABAZA

SOL

GRIS FRIOS / COOL GREYS

GRIS CÁLIDOS / WARM GREYS

COLOR / COLOUR

ACABADOS Y COLORES TENDENCIA

Trendy colours and finishes
/ finitions en couleurs tendance

Basándonos en las tendencias en moda y decoración, hemos elaborado una paleta de colores recomendados para esta temporada.

Esta gama cromática nace para servir de inspiración.

Nuestra producción nos permite lacar en cualquier tono de la carta NCS.

Based in fashion and decoration trends, we created a chart of recommended colours for 2015. This selection was born to be used as an inspirational collection. Any design can be produced in any color which is part of the NCS chart of colors.

En nous basant sur les tendances mode et la déco, et en élaborant une palette des couleurs recommandées pour cette saison 2015. Cette gamme chromatique naît comme outil d'inspiration. Notre production nous permet de laquer le meuble dans n'importe quel ton de la carte NCS.

* El fabricante se reserva el derecho de introducir los cambios y modificaciones que considere oportunos para la mejora del producto.

Los tonos pueden variar debido a causas técnicas de impresión.

* The manufacturer keeps the right to introduce any change or modifications, which are considered appropriate so as to improve our product.

The tones could vary because of technical printing causes.

* Le fabricant se réserve le droit d'introduire les changements et modifications qu'il considère opportuns dans le but de l'amélioration du produit.

Les tons pourraient varier dû à certaines causes techniques de l'imprimé.

MADERA / WOOD



ROBLE PRECOM BLANCO



ROBLE NATURAL



NOGAL NATURAL



ROBLE PRECOM WENGUE



ROBLE PO 159

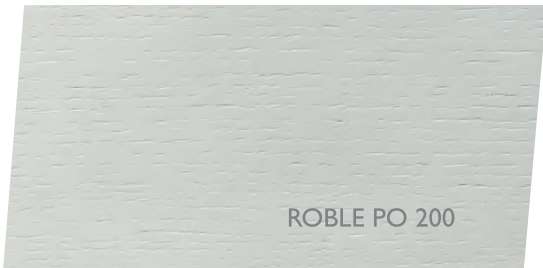

ROBLE PO 200

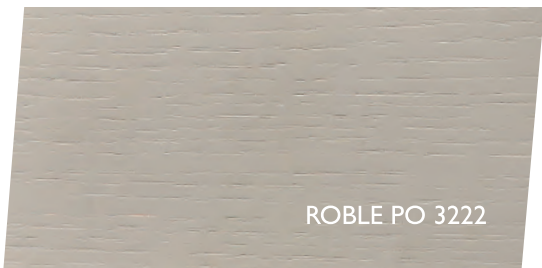

ROBLE PO 3222

LAMINADO / LAMINATED



ROBLE MEDITERRANEO CLARO



NÓRDICO CLARO



NÓRDICO OSCURO



ROBLE CLARO



ROBLE MEDIO



PINO OSCURO

LAMINADO VETA SINCRONIZADA / LAMINATED WITH SYNCHRONIZED RELIEF



Delta turns 25 and keep on pushing for innovation and sustainability of its products in order to make life easier to people. An assertion created the day Delta was set up.

EXCITED AS IF THE FIRST DAY

Thanks to the effort of a narrow group of people, this company was set up in 1989 dedicated to kitchen furniture manufactures. Nowadays, it has become a company dedicated to produce any kind of furniture and its facilities of more than 10,000 m2 allows Delta to be in 4 continents and have more than 200 stores.

Everything is done keeping the excitement and commitment of the first day: Innovation, Quality, Sustainability and Design.

INNOVATION, QUALITY AND GUARANTEE

In 2010 we show our model: Artica, design Estudiosat, a revolucionary kitchen which main interest is a door inspired in the digital world and decorated with a 3-dimensional design.

In 2011 we introduced Codel, a nanotechnology project applied to furniture. It increases steam and high temperatura resistance in any furniture surface. In 2013 we designed Kala, a new door with a finger-pull embedded.

A proof of our commitment with manufacturing and environmental requirements are our certifications: AENOR ISO 9.001 quality management certificate & AENOR ISO 14.001 Environmental management certificate. And we select our provider taking care that they have the PEFC certificate.

We offer 5 years warranty in our products.

Delta fête ses vingt-cinq ans avec le même engagement qu' au jour de sa naissance : parier sur l'innovation et la durabilité de ses produits pour vous faciliter le jour à jour.

LA MÊME ILLUSION DU PREMIER JOUR

Grâce au compromis d'un groupe réduit de personnes, naissait en 1989 une petite entreprise, qui se dédiait à la fabrication de meubles de cuisine, et qui a actuellement évolué vers un concept global de foyer ,avec ses cuisines, ses salles de bains , et avec plus de 10.000 m2 d'installations ,sa présence dans quatre continents, et ses plus de 200 points de vente en Espagne.

Tout cela en maintenant le même esprit du premier jour: projeter des solutions technologiques innovatrices, en misant sur la qualité, le soutenabilité et l' importance du design dans la création.

INNOVATION, QUALITÉ ET GARANTIE

En 2010 nous présentons le modèle Artica, une cuisine révolutionnaire projetée par Estudiosat, et qui brille par ses volumes tridimensionnels inspirés du monde digital.

En 2011 nous présentons Codel, un projet de nano-technologie appliquée au traitement superficiel du meuble qui augmente sa résistance à la vapeur et aux hautes températures. En 2013, nous développons Kala, une nouvelle porte avec le concept de poignée avec onglet intégré.

Nos certificats de qualité AENOR ISO 9.001 , et de gestion environnementale AENOR ISO 14.001 sont la preuve de notre compromis avec les exigences du marché et de l'environnement , ainsi comme notre sélection de fournisseurs qui possèdent la prestigieuse marque PEFC en gestion forestière.

Nous offrons 5 ans de garantie sur tous nos meubles.





Delta Cocinas Baño Habitat

Delta cumple veinticinco años con el mismo compromiso con el que nació: apostar por la innovación y la sostenibilidad de sus productos para hacer la vida más fácil a las personas.

Ilusionados como el primer día

Gracias al empeño de un reducido grupo de personas, la pequeña empresa que nació en 1989 para dedicarse a la fabricación de mobiliario de cocina, se ha convertido en la actualidad en concepto global de cocina, baño y hogar, con más de 10.000 m² de instalaciones, con presencia en cuatro continentes y más de 200 puntos de venta en España.

Todo ello manteniendo el espíritu del primer día: proyectar soluciones tecnológicas innovadoras, apostando por la calidad, la sostenibilidad y el diseño.

Innovación, calidad y garantía

En 2010 presentamos el modelo Artica, diseño Estudiosat, una cocina revolucionaria que destaca por sus volúmenes tridimensionales inspirados en el mundo digital.

En 2011 presentamos Codel, un proyecto de nanotecnología aplicado al tratamiento superficial del mueble, que incrementa su resistencia al vapor y las altas temperaturas. En 2013, desarrollamos Kala, una nueva puerta con el uñero integrado.

Prueba de nuestro compromiso con las exigencias del mercado y con el medio ambiente son las certificaciones de calidad AENOR ISO 9.001, de gestión ambiental AENOR ISO 14.001 y la selección de proveedores que cuentan con el prestigioso sello PEFC de gestión forestal.

Ofrecemos 5 años de garantía en todos nuestros muebles.



EXCLUSIVE PRODUCTION UNDER REQUEST

Every composition is unique. Its production is made under request and exterior design, as well as interior, is personalized. During its manufacturing process, any piece of the cabinets is examined following strict quality controls.

SINGULARITY: TOUCH AND COMPARE

We have got the technical resources to make good quality and durability finishes, way over the standards demanded by the market. These are our singularities:

CABINET CARCASS: 19mm,
Front edging 1mm,
Back panel two sided 6mm,
3 standard finishes,
Custom interior finish is also available.

3D ADJUSTABLE HINGES

Hettich made of stainless steel with an anti corrosion treatment.
Soft closing,
Tested 200.000 cycles of use.
3 hinges from 90 cm of height.

DRAWERS & DEEP DRAWERS

End and back panels made of lacquered steel by Hettich.
Holding 40 / 60 / 80 Kg.
Soft closing system.

LEGS which hold up to 280 Kg/ Leg.
Fixing by a expanding system.
Adjustable from 10 to 14 cm or from 15 to 19 cm.

Furniture HANGERS which hold up to 70 Kg.

FABRICATION EXCLUSIVE ET SOUS COMMANDE

Chaque composition est unique. Sa production se réalise sous commande et se personnalise autant en intérieurs comme pour nos concepts d' extérieurs. Pendant tout le procès, les composants du meuble sont contrôlés, suivant les contrôles de qualité qui correspondent à la commande du client.

LA DIFFÉRENCE: TOUCHEZ ET COMPAREZ AU TACT.

Nous disposons de ressources techniques qui nous permettent d'obtenir des finitions d'une qualité et d'une durabilité bien au-dessus des exigences du marché. Nous marquons cette différence notamment:

CHASSIS DU MEUBLE: 19 mm,
Front en chant de 1mm,
Arrière 6mm sur 2 faces,
3 finitions de série.
Possibilité de finitions intérieures personnalisées.

CHARNIÈRES REGLABLES 3D

High-tech d' acier traitement anti-corrosion,
Freinage hydraulique,
Testés sur 200.000 cycles d' utilisation.
3 charnières à partir de 90 cm de hauteur.

TIROIRS & CASSEROLIERS

Latéraux et arrières en acier laqué de Hettich.
Supportent 40 / 60 / 80 Kg,
Mecanismes à frein silencieux.

PIEDS supportent 280 Kg/ Pied
Fixation par système expansif.
Réglage 10-14 cm ou 15-19 cm sans surplus.

ACCROCHEURS meuble supportent 70 Kg

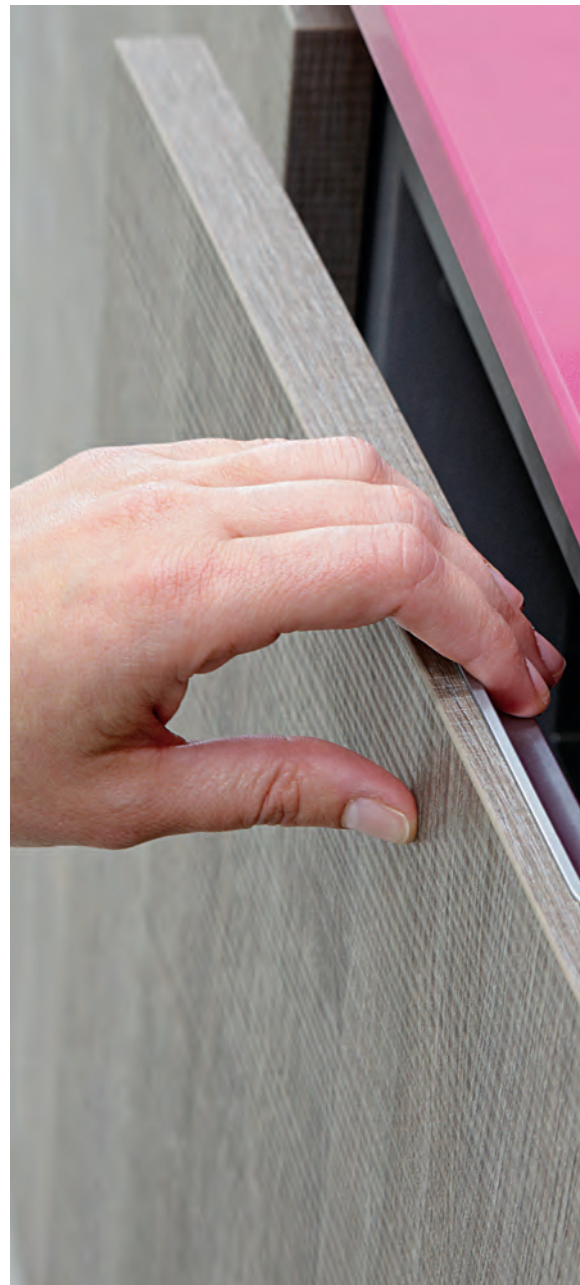
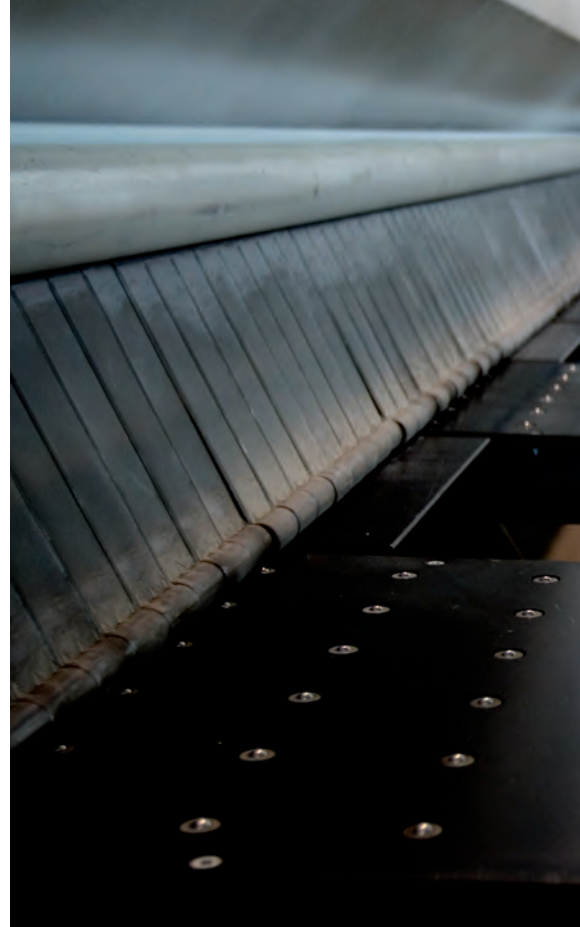



Fabricación exclusiva bajo pedido

Cada composición es única. Su producción se realiza bajo encargo y se personalizan tanto los interiores como el diseño exterior. Durante todo el proceso los componentes del mueble son inspeccionados siguiendo controles de calidad y correspondencia con el pedido de cada cliente.

Diferenciación: toque y compare

Disponemos de recursos técnicos que nos permiten obtener acabados de calidad y durabilidad por encima de lo exigido en el mercado. Nos diferenciamos objetivamente en:

ARMAZÓN MUEBLE: 19 mm
Frente canteado 1mm con cola PUR
Trasera 6mm a 2 caras
3 acabados interiores de serie
Posibilidad de acabado interior personalizado

BISAGRAS REGULABLES 3D
Hettich de acero tratamiento anticorrosión
Frenado hidráulico
Testadas 200.000 ciclos de uso
3 bisagras a partir de 90 cm altura.

CAJONES & CACEROLEROS
Laterales y traseras acero lacado de Hettich.
Soportan 40 / 60 / 80 Kg
Mecanismos con freno silencioso

PATAS soportan 280 Kg/ Pata
Fijación mediante sistema expansivo.
Regulación 10-14 cm ó 15-19 cm sin incremento.

COLGADORES muebles soportan 70 Kg



 **Delta** Baño



 **Delta** Cocinas Baño Habitat

Polígono Martín Grande nº5
26550 Rincón de Soto, La Rioja (España)

Tel. 941 160 669

Fax 941 160 681

delta@deltacocinas.com



siguenos en: **flickr**™  
www.deltacocinas.com
www.deltabaño.com

